

UTOPIA SERIES

PORTABLE SPA

OWNER'S MANUAL

GENEVA • NIAGARA

TAHITIAN



Caldera SpasTM

**QUALITY SPAS
AND GAZEBOS SINCE 1976.**

TABLE OF CONTENTS

IMPORTANT SERVICE INFORMATION	1	BALANCING THE SPA WATER	
IMPORTANT SAFETY INSTRUCTIONS	2	• Balancing your spa water (first time)	17
SET UP AND INSTALLATION		• 3-day-a-week spa care program	17
• Site selection and preparation	3	WATER MAINTENANCE	
• Equipment compartment access	3	• Water purification with Ozone	18
• Electrical installation	4	• Alkalinity Table	18
START-UP INSTRUCTIONS		• pH Level Table	18
• Installing the spa cover	6	• Sanitizer Level Table	18
• Top view-features illustration	6	SPA WATER TROUBLESHOOTING	19
CUSTOMIZING YOUR MASSAGE		SPA TROUBLESHOOTING	
• Power Diverters, Air controls & Hydro jets	7	• Basic Troubleshooting	20
• Power Diverter functions	7	• LCD messages	21
OPERATION		SPA SPECIFICATIONSBack cover
• Spa-side controls	8		
• Touch pad controls	9		
• Standard or Economy mode	9		
• Skim/Filter cycles	9		
• Changing Skim/Filter cycles	10		
• Panel Lock (spa-side control)	10		
• Temperature Lock/Unlock	11		
• Fiber Optics Lighting operation	11		
• Caldera Pure Water Ozone system	11		
MAINTENANCE			
• Important maintenance procedures	12		
• Equipment compartment illustration	13		
• Filter removal and maintenance	14		
• Fiber Optics Lighting	14		
• Power Diverter maintenance	14		
• Spa cover care	15		
• Non-operation in a cold climate	15		
• Winterizing your spa	15-16		
• Draining your spa	16		

IMPORTANT SERVICE INFORMATION

Congratulations on your new ownership of a quality Caldera portable spa.

This manual will help you with every aspect of operation as well as provide helpful information on how to care for your spa. With proper maintenance, your Caldera spa will provide you with many years of relaxation and dependable service.

If you have any questions not addressed in this manual, call your Caldera dealer and he or she will be happy to assist you.

Pictured below are the Caldera Data labels that are located in the spa equipment compartment. Locate and read these labels, then fill out the blanks below with the corresponding information.

If replacement parts are needed, it is important that you have the complete Data Label information for your dealer or service organization.

Retain this manual for future reference. Please have the information below readily available if you need to contact your Caldera dealer for service or repair.

Dealer: _____

Address: _____

Phone: _____

Date of purchase: _____

Electrician: _____

Installation date: _____

Spa serial #: _____

Model #: _____

Optional equipment:

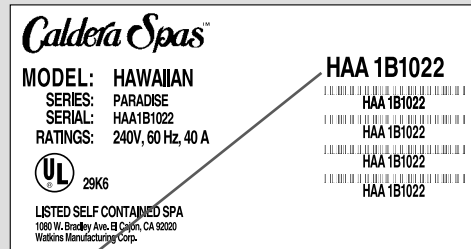

NOTE: This is an example. Your spa's label will contain different information.

IMPORTANT SAFETY INSTRUCTIONS

READ AND FOLLOW ALL INSTRUCTIONS

1. DANGER - RISK OF ACCIDENTAL DROWNING.

Extreme caution must be exercised to prevent unauthorized access by children. To avoid accidents, ensure that children cannot use this spa unless they are under adult supervision at all times.

2. WARNING - TO REDUCE THE RISK OF INJURY:

A. A bonding lug has been provided on the outside of the Control Module electrical control box. This lug permits the connection of No. 6 AWG solid copper bonding conductor between the Control Module and all other electrical equipment and exposed metal in the vicinity, as may be needed to comply with local regulations.

B. The suction fittings in this spa are sized to match the specific water flow created by the pump. Should the need arise to replace the drain-suction fittings or the pump, be sure that the flow rates are compatible. Never replace a suction fitting with one rated less than the flow rate marked on the original suction fitting. Never remove, or alter in any way, the covers on the drain-suction fittings in the spa. Never operate the spa if the covers on the drain-suction fitting are broken or missing.

C. To eliminate the risk of electrical shock install the spa at least 5 feet (1.5m) from all metal surfaces. (A spa may be installed within 5 feet of metal surfaces if each metal surface is permanently connected by a minimum No. 6 AWG solid copper conductor attached to the wire connector on the terminal box that is provided for this purpose.

D. Do not permit any electrical appliances such as a light, telephone, radio or television within 5 feet (1.5m) of the spa.

E. The spa must only be hard wired to a supply circuit that is protected by a ground fault circuit interrupter (GFCI). Such a GFCI is required by most building codes, should be provided by the installer and must be tested before each use. Consult GFCI manufacturers instructions for correct testing and operation.

F. The water in a spa should **NEVER exceed 40 degrees C (104°F)**. Water temperatures between 100°F and 104°F are considered safe for a healthy adult. Lower water temperatures are recommended for extended use (exceeding 10-15 minutes) and for young children.

G. Since excessive water temperatures have a high potential for causing fetal damage during the early months of pregnancy, pregnant or possibly pregnant women should limit spa temperatures to 100°F.

H. Before entering the spa, the user should measure the water temperature with an accurate thermometer since the tolerance of water temperature regulating devices may vary as much as ± 5 degrees.

I. The use of alcohol, drugs, or medication before or during spa use may lead to unconsciousness with the possibility of drowning.

J. Persons suffering from obesity or with a medical history of heart disease, low or high blood pressure, circulatory system problems or diabetes should consult a physician before using a spa.

K. Persons using medication should consult a physician before using a spa since some medications may induce drowsiness while other medications may affect heart rate, blood pressure and circulation.

L. Because occasional users of the spa may not be aware of all the potential risks associated with spa usage, they should be made aware of these important safety instructions.

M. The electrical supply for this product must include a suitably rated switch or circuit breaker to open all ungrounded supply conductors to comply with the National Electrical Codes. The disconnection means must be within sight and readily accessible to the spa occupants but installed at least 5 feet (1.5m) from the spa water. (For permanently connected units not provided with an integral disconnecting means).

N. All units must be installed to provide drainage of compartment for electrical components.

O. Be sure that water always flows freely from the hydrotherapy jets within the spa. Any blockage or restriction of this water flow by persons or objects may damage system components, create an electrical shock hazard, and/or cause water damage to the surrounding area.

P. To avoid damage to the pump and heater, the spa must never be operated unless the spa is filled with water.

SAVE THESE INSTRUCTIONS

SET UP AND INSTALLATION

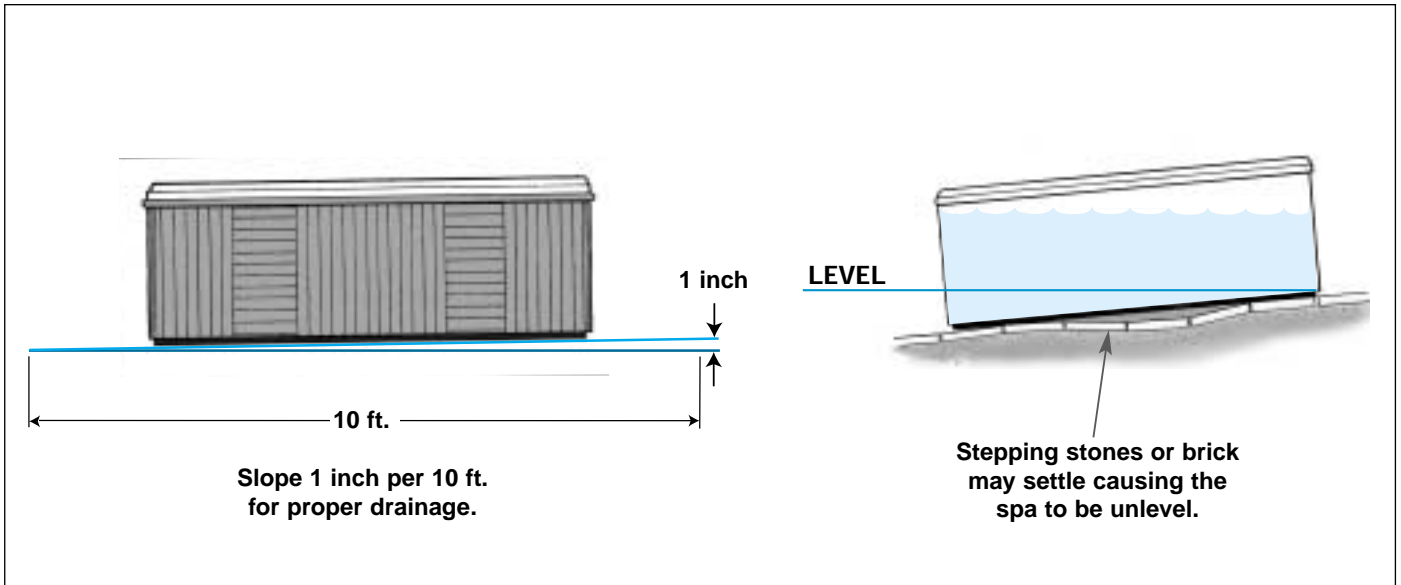

SITE SELECTION

In order for your spa to function properly, it must be placed on a SMOOTH, LEVEL, SELF-DRAINING SURFACE.

Concrete sloped at 1 inch per 10 feet is preferred so that rain water and water spillover will run off and not puddle underneath the spa (water under the spa for long periods of time may cause the wood to deteriorate). Other options are brick, stepping stone or blocks.

It is important to note that soft surfaces, even when stepping stones are used to evenly distribute the weight of the spa, will have a tendency to settle, thus resulting in an unlevelled spa.

INSTALLATION ON A WOOD DECK - Wood decking requires that the deck must be constructed to support at least 80 pounds per square foot. Individual spa weight per square foot will vary. Refer to a licensed contractor for proper structural support.

Refer to the SPA SPECIFICATIONS table on the back cover for spa dry weight and spa weight with water.

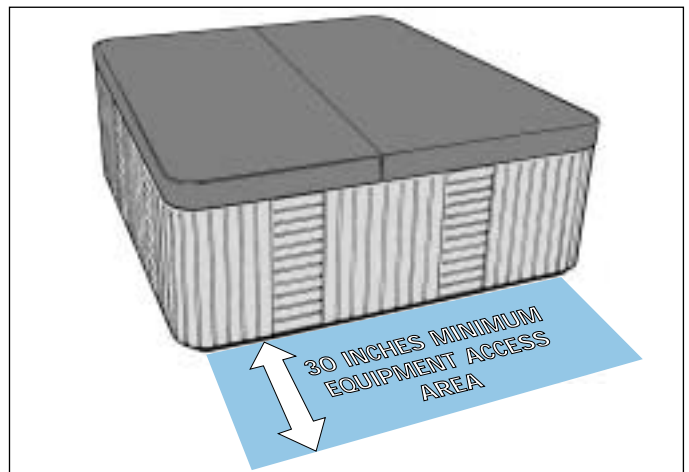

EQUIPMENT COMPARTMENT ACCESS

When considering an installation site, always allow for a minimum access space of 30 inches in front of the equipment compartment of the spa. This provides adequate clearance for future service if necessary.

If accessory items will be installed on or around the spa (gazebos, steps or planters), allow for additional space around the spa's perimeter.

Please Note: Placing the spa on grass or dirt may increase the amount of debris which is inadvertently brought into the spa water and may cause harm to your equipment as well as the spa surface, and is not covered under warranty.

Please note: Some cities and counties may require a permit for installation of electrical circuits or the construction of exterior structures (decks and gazebos). In addition, some counties may require permits for the installation of a portable spa. Check your local codes for compliance.

ELECTRICAL INSTALLATION

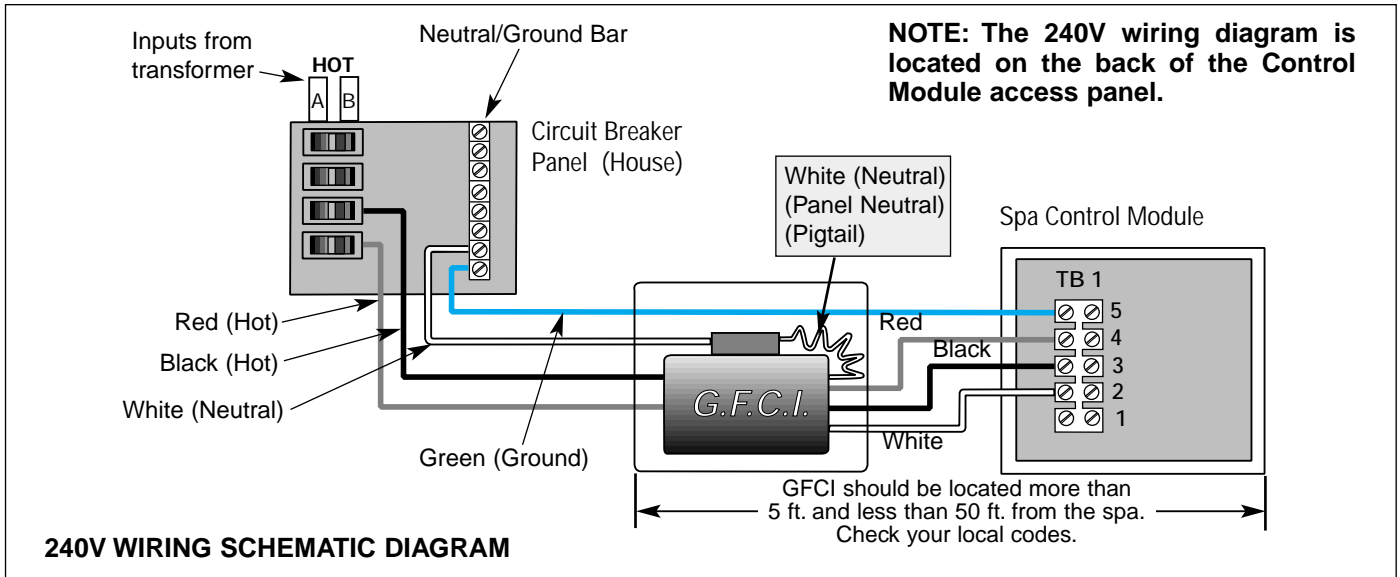

240 VOLT INSTALLATION

Your spa contains a Control Module designed to operate at 240V, 60Hz. Installation of a 50 amp. dedicated circuit is required. The Control Module must be hard wired directly to a supply circuit that is protected by a Ground Fault Circuit Interrupter (GFCI).

IMPORTANT NOTE: All electrical connections to the Control Module must be accomplished by a qualified electrician in accordance with the National Electrical Code and in accordance with any local electrical codes in effect at the time and place of installation.

All electrical connections must be made in accordance with the wiring information contained in this manual and on the back of the field wiring access panel of the Control Module.

For all permanently connected units not provided with integral disconnecting means: The electrical supply for this product must include a suitable rated switch or circuit breaker to open all ungrounded supply conductors to comply with local and national Electrical Codes. The disconnecting means must be within sight, and readily accessible to the user of the spa, but installed at least 5 feet (1.5m) from the spa.

The Control Module requires a 6 AWG copper, four-wire electrical service (Line 1, Line 2, Neutral and Ground), and requires a minimum supply conductor ampacity of 50 amperes. Failure to connect a neutral line will cause the Control Module to malfunction and will void the Control Module warranty.

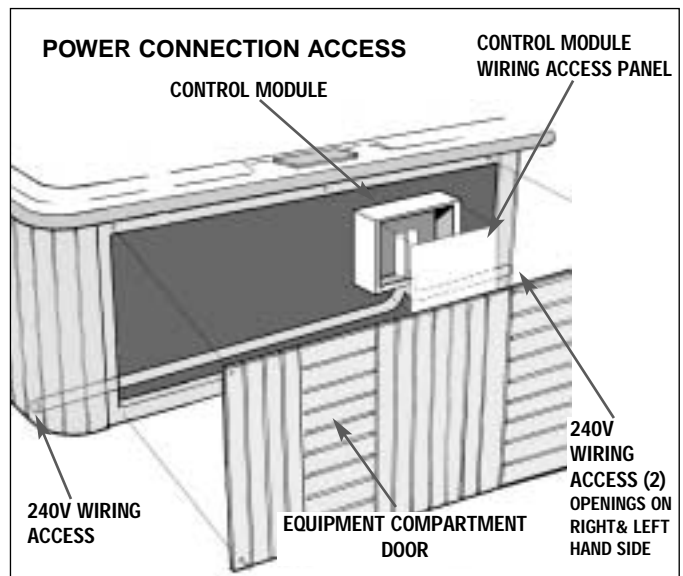

POWER CONNECTION To connect power to the spa, refer to “240 VOLT WIRING SCHEMATIC DIAGRAM” and “POWER CONNECTION ACCESS” illustrations above, then proceed with the following steps:

1. Remove the screws securing the equipment compartment door and remove the door.
2. Remove the screws securing the Control Module wiring access panel and remove the panel to allow access to the input power wiring.

NOTE: The 240V wiring diagram is located on the inside of the Control Module access door.

START-UP INSTRUCTIONS

Once the spa is placed on a proper foundation and connected to the appropriate electrical service, the spa may be filled and made ready for use. For best results, read each step in its entirety before proceeding with that step.

IMPORTANT - Do not activate power until the spa is filled. To avoid damage to the spa's equipment, the pumps must never be operated unless the spa is filled with water.

1. PREPARE SPA FOR FILLING

- Clear all debris from the spa.
- Although the spa shell has been polished at the factory, you may want to treat it with a specially formulated spa cleaner and wax available from your dealer prior to filling it for the first time.
- Before filling your spa for the first time, refer to the "EQUIPMENT COMPARTMENT" illustration on page 13 and perform the following procedures to ensure proper operation:
 - Remove the equipment compartment door.
 - Check all pump unions to ensure that they are hand-tight.
 - Check that all knife valves are in the open position. (Clear, plastic tubing has been factory-installed around the shaft of each of these valves to keep them from inadvertently closing. This step is a precautionary measure to ensure that these valves have not closed during shipping.)
 - Install pump drain plugs, if necessary. (During winter months, the pumps' drain plugs are removed to prevent possible freeze damage during shipping and storage. If this is the case with your spa, there will be a notice to this effect taped to the front of the spa's control box and the drain plugs will be in the plastic bag that includes the owner's manual.)

2. FILL THE SPA

NOTE: Never fill your spa with water from a water softener. Its corrosive effects will damage your spa's components.

- Remove the skimmer basket and weir - see page 14.
- Insert the end of a garden hose into the filter canister and begin filling the spa.
- Stop filling when the water level is approximately one inch above the highest jet.
- Reinstall the skimmer basket and weir.

3. TURN ON POWER

Turn on power to the spa at the home's circuit breaker, Ground Fault Circuit Interrupter (GFCI) and any other switching devices installed by your electrician. When power is on, the spa's LCD screen will display information.

4. ACTIVATE JETS

- Set all air controls to the "Max" position to help you see which jets are being activated. See illustration on page 6.
- Press the  touch pad on the control panel twice to turn on the high speed of the dual-speed pump - see "SPA SIDE CONTROLS" illustration on page 8.



• You should be able to feel a steady stream of water from at least some of the jets. If not, refer to the instructions for priming the pump in the SPA TROUBLESHOOTING section in the back of this manual.

- Press the  touch pad twice more to turn on the single-speed pump. Once a steady flow of water is detected from some of the jets, press this touch pad once more.

5. ADD START-UP CHEMICALS

Add the spa water chemicals as directed by your Caldera dealer, by the instructions contained in your spa chemical kit or in the section titled "BALANCING THE SPA WATER" on page 17.

6. SET TEMPERATURE

Your spa has been pre-set to automatically achieve a water temperature of 100°F, which is the temperature typically preferred for comfortable spa enjoyment. If you prefer a different temperature, press either the  or  touch pad to display the temperature which has been set. Then, each time either of these pads is pressed again (within five seconds), the set temperature will increase or decrease depending on which pad is pressed.







- The maximum temperature for which the spa can be set is 104°F and the minimum is 80°F.
- The set temperature may be locked to prevent unauthorized adjustment. See page 11.

DANGER. RISK OF INJURY. Always check the water temperature carefully before entering the spa.

7. SET SPA TO HEAT

- Press the  touch pad until the "Standard" indicator appears on the control panel's LCD screen. This allows the heater to run continuously until the set temperature is achieved. (See "STANDARD OR ECONOMY MODE" on page 9.)
- The time required for initial heat-up will vary depending on the temperature of the fill water and the size of the spa. You may expect a temperature rise of approximately 4 to 6 degrees per hour for larger spas and about 8 to 10 degrees per hour for small spas.

8. SET TIME OF DAY

- Press  then press  to enter the time-setting mode.
- Note the correct time of day, then press  once to advance the time setting or  to decrease the time setting. (Notice that AM and PM indicators appear to the left of the main four-digit display on the LCD screen). The time of day will advance slowly for ten seconds, then rapidly.
- When the correct time of day is reached, press either  or  to stop the time from changing.
- To exit the time-setting procedure, press the  touch pad.

START-UP INSTRUCTIONS

9. INSTALL THE SPA COVER

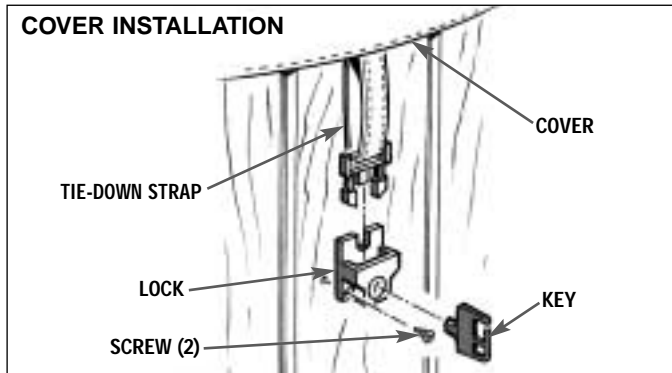

- Place the cover squarely on the spa.
- Position the tie-down locks included with your cover on the

side of the spa so that they are easily reached by the cover tie-down straps. Allow for about 1/2" to 3/4" slack in the straps to make it easy to insert straps into locks and to compensate for vinyl shrinkage in cold weather.

- Attach the locks with the screws provided and insert the cover tie-down straps into the locks.

Keeping the cover in place any time the spa is not in use will reduce the amount of time the heater operates, thereby minimizing operating costs.

DANGER. RISK OF INJURY.

- Never leave a spa uncovered or unattended.
- Never leave a spa cover unlocked.
- Do not stand, sit or lie on the cover.

TOP VIEW - FEATURES

1. Power diverter
2. Air control
3. Air jets
4. Whirlpool jet
5. Filter compartment
6. Main spa-side control panel
7. Temperature sensor
8. Spa light
9. Euphoria jet
10. Drain/suction fitting
11. Ozone inlet
12. Auxiliary control panel

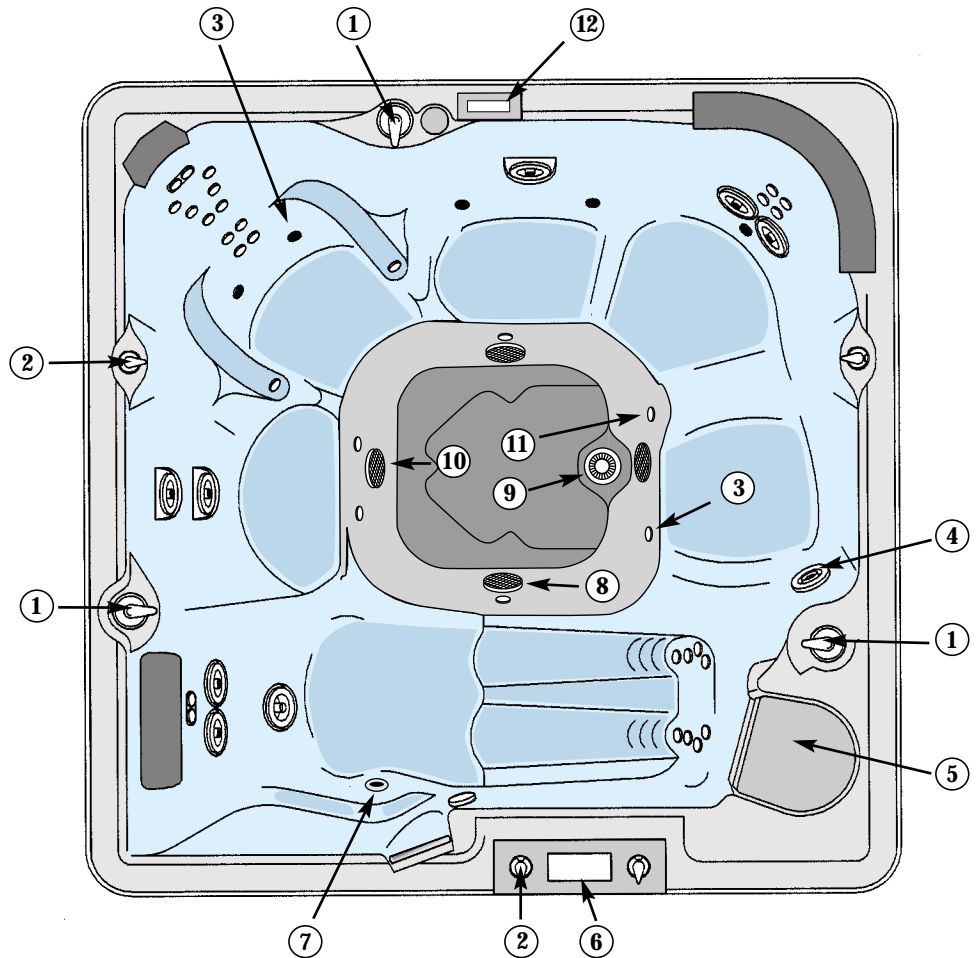

**GENEVA MODEL SHOWN.
LOCATION OF FEATURES VARIES IN OTHER MODELS.**

CUSTOMIZING YOUR MASSAGE

Your Caldera spa offers numerous ways for you to customize your massage experience. Experimentation is the best way to find what feels best to you. Try sitting in different seats, adjusting the Power Diverters, air controls and jet nozzles and turning different pumps on or off.

POWER DIVERTERS

Using the Power Diverters, you can direct the flow of water from the pumps to various combinations of jets.

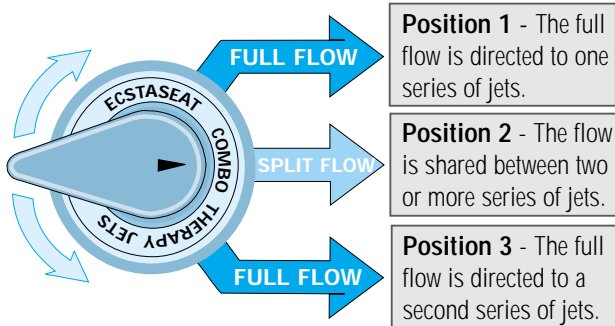

The functions of these Power Diverters can best be learned by experimentation as follows:

1. Set all air controls to the "MAX" position.
2. Turn on the high speed of both pumps.
3. Note the labels on the Power Diverters and turn the handles and see which groups of jets are affected. (Note that you can adjust the Power Diverters to any position between the two possible extremes to achieve the jet pressure that feels best to you.)

Niagara & Geneva Models

NOTE: One of the Power Diverters on these models operates only if the Power Diverter on the left side of the spa (when standing at the control panel) is positioned to "Valve #2" or "Combo".

AIR CONTROLS

Each jet system has its own air control. These allow you to change the power of the jets by regulating the amount of air that is mixed with the water coming out of the jets.

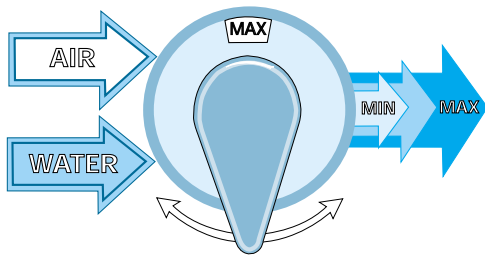

TIP: Turn both pumps on high speed and position the Power Diverters to "Combo". Then experiment with each of the air controls to see their effect.

HYDRO JETS

VersaSsage Jets - These jets can be adjusted to provide either a stationary, direct stream or, by positioning the nozzle to one side or the other, a variety of rotating massage patterns.

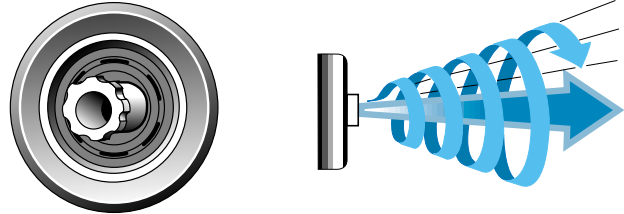

Versa Jets - The direction of the water stream can be redirected by repositioning the nozzle. You may convert any Versa jet to a VersaSsage jet with a replacement nozzle available from your Caldera dealer.



Euro and Euro-pulse Jets - The small euro jets deliver a direct, precision massage. Many of these jets feature a special insert that creates a soft, pulsating, rotary massage. The roto jet cap assemblies may be removed if you want a more powerful, direct massage in a particular location. To do this, gently pry around the outside edge of the cap assembly with a table knife, screwdriver or similar tool. If you desire, you may install a roto jet cap removed from one jet onto a standard euro jet simply by snapping the assembly into place. You may purchase additional roto jet assemblies from your Caldera dealer.

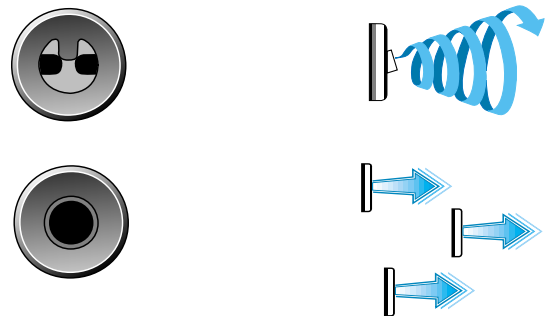

AIR JETS

The air jets deliver air bubbles to provide a subtle pulsation for gentle, soft-tissue massage.



OPERATION

SPA-SIDE CONTROLS

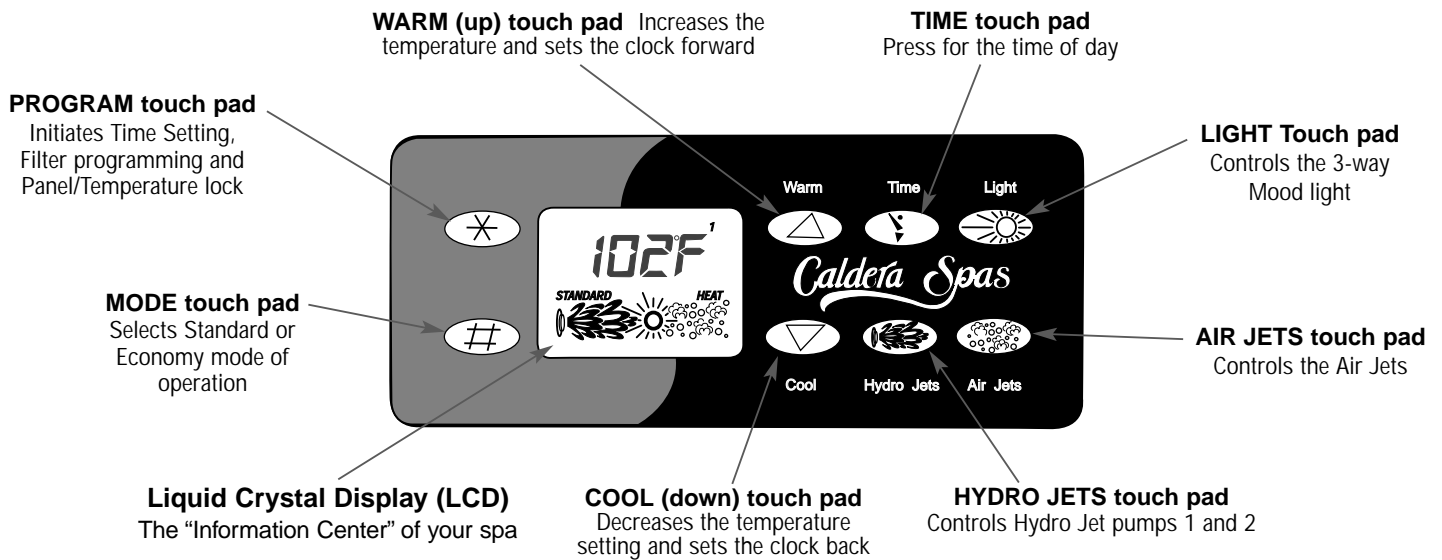

SPA-SIDE CONTROL PANEL

SPA-SIDE CONTROL OPERATION

Your spa-side control system consists of an illuminated Liquid Crystal Display (LCD) and convenient touch pads that



allow you to set the water temperature and adjust the skim/filter cycle settings, as well as control the hydrotherapy jets, air jets and mood light from spa side.

LIQUID CRYSTAL DISPLAY (LCD)

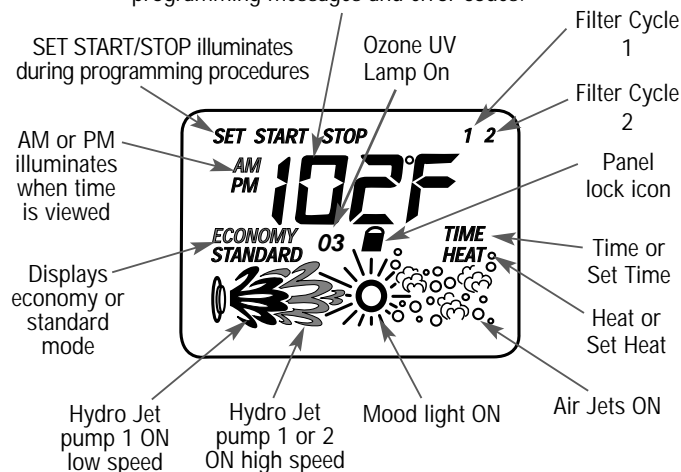
Continually displays the current temperature. Also temporarily displays the time of day, programming messages and error codes.



OPERATION - TOUCH PAD CONTROLS

DISPLAY INVERSION You may invert the main, four-digit display for easier viewing from inside the spa. Press either  OR , then  within three seconds.



Warm

TEMPERATURE To display the set temperature for three seconds, press either WARM or COOL. To change the set temperature, while the set temperature is displayed, press WARM to increase or COOL to decrease the set temperature.



Cool



Hydro Jets

Pressing the HYDRO JETS touch pad sequences the operation of the pumps as follows:

1. Dual-speed pump on low speed.
2. Dual-speed pump on high speed.
3. Single-speed pump on, Dual-speed pump on high speed.
4. Single-speed pump on, Dual-speed pump off.
5. Both pumps off (except during automatic functions).

The pumps automatically turn off after operating for 15 minutes.

Hydro Jet pump 1 and 2 will operate automatically whenever a filter cycle is activated or when a potential freezing condition is detected. If automatically activated, the pumps cannot be turned off with the Hydro Jet touch pad.



Air Jets

Press the AIR JETS touch pad to start or stop the air jets. **The air jets operate for 15 minutes, then automatically shut off.**



Light

The LIGHT touch pad allows you to select from three different settings. Press the LIGHT touch pad once to turn on the brightest setting. Press a second time to turn on the intermediate setting, and again for the dimmest setting. Press the touch pad a fourth time to turn off the light. **The light automatically turns off after 4 hours of operation.**

(NOTE: If your spa is equipped with the optional fiber optics lighting package, refer to page 11 for operation instructions.)



Time

Press the TIME touch pad to temporarily display the time of day, press again to view the set temperature. Current spa temperature display will automatically resume after 3 seconds. See "SET TIME OF DAY" on page 5.



The PROGRAM touch pad is used to initiate time setting, programming filtration cycles and panel/temperature lock routines.



The MODE touch pad switches between the standard and economy operating modes and is used in various other programming sequences.

STANDARD OR ECONOMY MODE Press the MODE touch pad to select either standard or economy operation. When in standard mode, "STANDARD" will appear on the LCD. The spa water temperature is maintained at the set temperature at all times.

When in economy mode, "ECONOMY" will appear on the LCD. The heater operates only during skim/filter cycles to heat the spa water with the following exception: Should the spa water temperature fall below 20°F of set temperature, the heater will engage to heat the spa water to within 15°F of the set temperature.

SKIM/FILTER CYCLES Your spa will perform two skim/filter cycles each day. These cycles are factory pre-set to begin at 2 AM and 2 PM. You may adjust the cycle settings by following the instructions in the section titled "CHANGING SKIM/FILTER CYCLES" on the next page. The number 1 or 2 appears in the top right corner of the LCD screen to indicate which filter cycle is in progress. At the beginning of each cycle, the air jets turn on for 30 seconds to clear the air supply tubes and the single-speed pump turns on for one minute.

On spas without the continuous filtration system, the dual-speed pump's low speed operates for the entire duration for which the filter cycle is programmed. Also, the optional ozone generator on these models operates only during filter cycles.

OPERATION

CHANGING SKIM/FILTER CYCLES If the preset times are inconvenient, if a different duration is preferred, or if you wish to leave the heater off during filtering, the following procedure can be used to change the automatic filter cycle settings.

SKIM/FILTER CYCLE 1

PRESS **THEN PRESS** **THEN PRESS**

Time of day will be shown "SET TIME" message will appear on LCD "SET START" and "1" messages appear

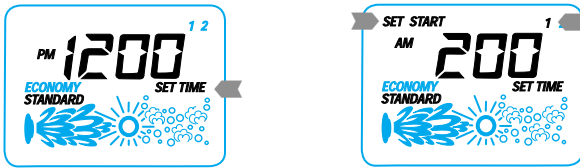

When "SET START" and "1" are displayed on the LCD: Press either the or touch pad to initiate time change. Press either touch pad again to stop time change.

THEN PRESS The "SET HEAT" and "ON" message appear on the LCD

You may now set the controls to either allow the heater to turn on as needed or to keep the heater from turning on during this filter cycle.

PRESS **OR PRESS** **THEN PRESS**

For heater "ON" For heater "OFF" "SET", "STOP" and "1" messages appear

PRESS **OR PRESS** **THEN PRESS**

To forward stop time To set back stop time "SET", "STOP" and "2" messages appear

After completing skim/filter 1 setting procedures above, continue on to set skim/filter cycle 2. Or, if you wish to exit, press .

SKIM/FILTER CYCLE 2 To change the settings for skim/filter cycle 2, follow the same procedure outlined in skim/filter cycle 1 above.

Note: The procedures for skim/filter cycle 1 and 2 are the same except the number 2 will appear in the upper right corner of the LCD instead of the number 1.

Press to exit skim/filter cycle 2 programming. The LCD will display the current water temperature.

Note: If the 24 hour message appears on the LCD, do not attempt to change the setting, Press .

PANEL LOCK The spa-side control panels may be locked to prevent unauthorized use of your spa. When the panel lock is engaged, all automatic spa functions continue to operate normally.

NOTE: The touch pads utilized for the lock procedure must be pressed within 3 seconds to activate the lock. Within 3 seconds the LCD will display the current water temperature and the lock icon. All spa-side control panel touch pads and remote control panel touch pads will be deactivated except the program touch pad, which is used to initiate the unlock sequence.

TO LOCK THE PANEL The steps to lock the panel are outlined below. Note the LCD read-out as you proceed through the panel lock procedures.



PRESS **THEN PRESS** **THEN PRESS**

TO UNLOCK THE PANEL



PRESS **THEN PRESS** **THEN PRESS**

All three touch pads must be pressed in the correct sequence and within 3 seconds. When the last touch pad is pressed, the lock icon will disappear and all touch pads will be active again.

OPERATION

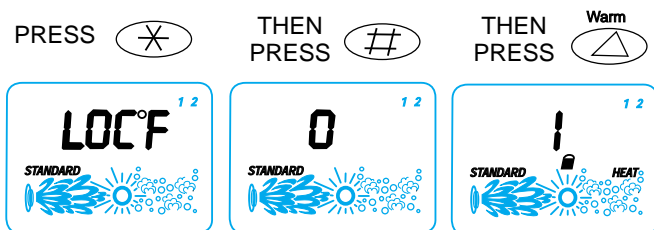
TEMPERATURE LOCK The temperature lock is provided to prevent unauthorized temperature adjustment of your spa water. While setting your spa water temperature, after you have pressed the  or  touch pad, follow the instructions below to lock the set temperature. When the temperature lock is engaged, all automatic spa functions will operate normally.



The set lock touch pads must be pressed within 3 seconds to activate the lock. When locked, the LCD will display the current spa temperature, the lock icon and "SET HEAT". The temperature  and  touch pads will be deactivated; when pressed, the set temperature will appear on the LCD with a double arrow next to it.

TEMPERATURE UNLOCK To unlock the temperature, follow the instructions under "TO UNLOCK THE PANEL" on page 10.

AUTOMATIC DEFAULT Your spa is equipped with a 30-day battery back-up to preserve your custom settings, if any. If power is disconnected from the spa for longer than 30 days, all settings will revert to the original factory settings.

OPERATION OF FIBER OPTICS LIGHTING OPTION

This option replaces the standard spa light. Disregard the "Light" operating instructions on page 9.

FIBER OPTICS LIGHTING - MANUAL OPERATION

Pressing the  touch pad operates the fiber optics lighting as follows:



FIBER OPTICS LIGHTING - AUTOMATIC MODE

The fiber optics lighting option is programmed to automatically turn on between 6 PM and 12 AM daily. To turn the automatic mode off:

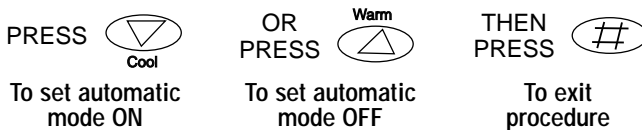
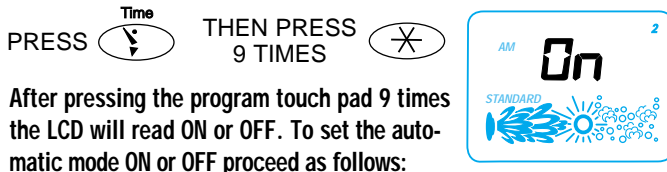

CALDERA PURE WATER OZONE SYSTEM - OPTION

The optional Ozone Generator operates during filter cycles to disburse ozone into the spa through an ozone jet located in the footwell of the spa. Water flow from the ozone system should be checked periodically; small bubbles should be seen rising from the ozone jet.

When the ozone generator's UV lamp is operating properly, "O3" displays on the LCD screen. If this indicator is not displayed when the ozone generator should be operating, the UV lamp is burned out and needs to be replaced.

MAINTENANCE

IMPORTANT MAINTENANCE PROCEDURES

3 days a week

Check water level. Make certain water level is 1 inch above the highest jet.

Check and adjust Chlorine level to 1.0 to 3.0 ppm if Chlorine is used as sanitizer. If Bromine is used, check weekly.

Once a week

Test the spa water using test strips or test kit.

Adjust pH and total alkalinity - refer to pH and total alkalinity on label of SPA UP and SPA DOWN.

Check and adjust Bromine level to 1.0 to 3.0 ppm if Bromine is used as sanitizer. If Chlorine is used, check three times a week.

Add 1 ounce of SPA DEFENDER per 400 gallons of water to prevent calcium build up.

Shock treat with 2 ounces of RENEW, a non-chlorine shock.

Check and clean the skimmer basket and weir to insure proper filter flow, remove leaves, foreign matter and debris.

Check spa cover. Make certain cover is positioned properly and tie-down straps are fastened/locked. Be sure water and snow are swept off or kept from accumulating or puddling on the cover.

**IMPORTANT:
KEEP SAND AND GRIT OUT OF SPA**

Sand and grit will damage or impair the performance of your spa's components. Use caution to avoid tracking debris into the spa. Remove sand or grit from the spa as soon as you notice it is present. A spa vacuum designed for this purpose is available from your Caldera dealer.

Four to six weeks

Inspect and clean the spa filter cartridge. It is very important to maintain your spa filter cartridge and keep it clean and free of particles which can restrict water flow. If the filter is not cleaned on a regular basis, the filter may clog and restrict water flow, which causes improper filtration and poor jet performance. See "FILTER CARTRIDGE REMOVAL AND CLEANING INSTRUCTIONS" on page 14.

Two months (heavy usage) Five months (light usage)

Drain your spa. Follow the procedures outlined in "DRAINING YOUR SPA" on page 16. Clean the spa with "Spa Multi-Purpose Cleaner" and then polish with a silicone sealant polish. When refilling your spa be sure to follow the "START-UP" instructions on page 5.

Six months

Clean and seal your spa skirt. The spa skirt is coated with a tinted stain for protection and to enhance the beauty of the natural redwood. Like all wood products, prolonged exposure to the weather and climate conditions will cause the redwood to discolor or fade. To maintain the rich finish, apply a good quality tinted or clear stain every six months.

Note: The stain used by Caldera is available from your Caldera dealer.

MAINTENANCE

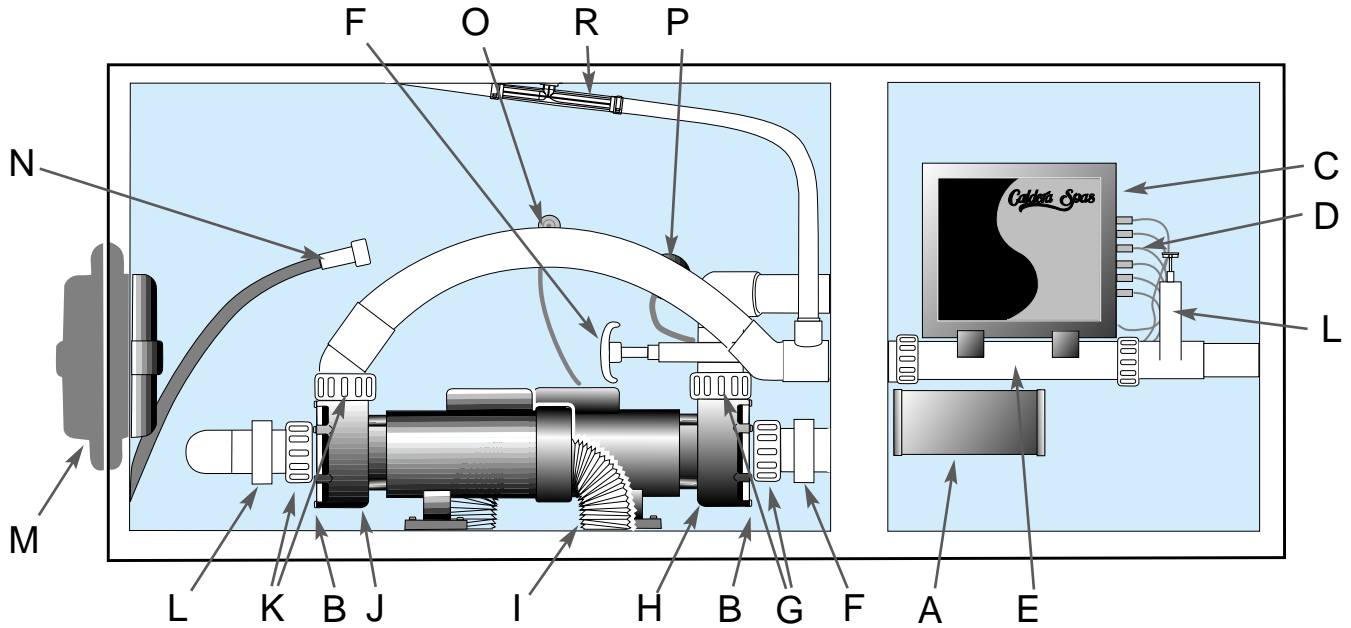

TYPICAL EQUIPMENT COMPARTMENT

LEGEND - TYPICAL EQUIPMENT COMPARTMENT

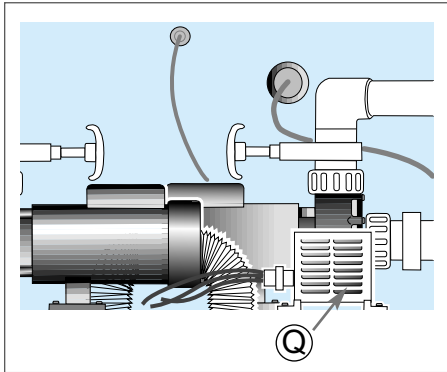

FIBER OPTICS LIGHT

- | | |
|--|---|
| A. Caldera Pure Water Ozone system. (Option) | J. Hydro jet pump # 1. |
| B. Pump drain plugs. | K. Union (2), Hydro jet pump # 1. |
| C. Control Module/wiring access panel. | L. Knife Valve (2), Hydro jet pump # 1. |
| D. Plugs/receptacles - spa component connection. | M. Air pump. |
| E. Spa water heater. | N. Drain hose with drain cap. |
| F. Knife Valve (2), Hydro jet pump # 2. | O. Temperature sensor. |
| G. Union (2), Hydro jet pump # 2. | P. Underwater light. |
| H. Hydro jet pump # 2. | Q. Fiber optics module. |
| I. Pump motor cooling duct. | R. Ozone injector (Option) |

MAINTENANCE

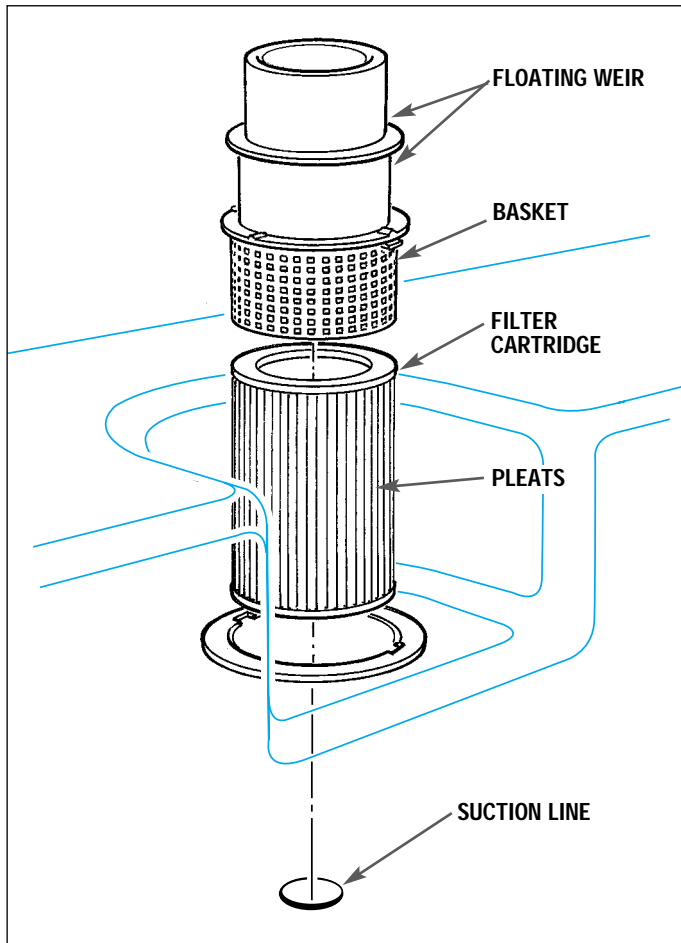

FILTER CARTRIDGE REMOVAL AND CLEANING INSTRUCTIONS

Turn the power to the spa OFF, then proceed as follows:

1. Push down slightly and turn filter basket counter-clockwise to unlock, then pull the basket and weir out.
2. Carefully pull up the filter cartridge and bring it out of the spa.
3. Rinse cartridge using a garden hose. Rotate and separate filter pleats while spraying water to remove all debris possible. Let the filter dry and then look for calcium deposits (scaling) or an oil film. If you find these, you will need to deep clean your filter cartridge with a "spa filter cleaning" solution to break down and remove mineral deposits and oils.
4. To return basket and weir, insert and rotate clockwise to lock into position. Then, turn spa's power back on.

Note: The filter cartridge should be replaced with a new cartridge approximately every 12 months. Replacement filter cartridges are available from your Caldera dealer. Refer to the back of this manual to determine the appropriate size for your spa.

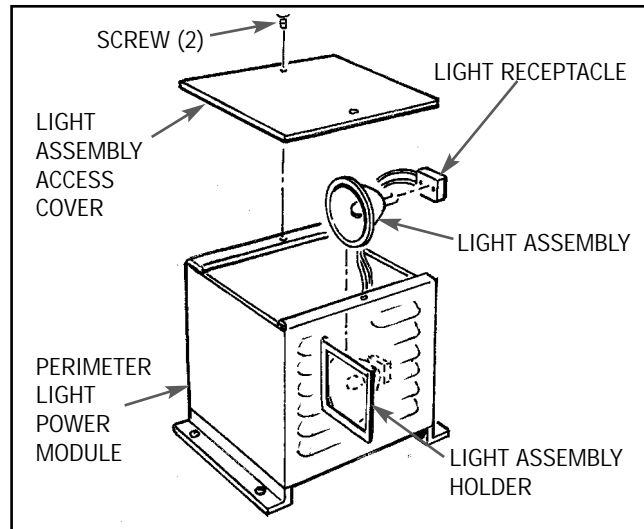

FIBER OPTICS LIGHT

LIGHT ASSEMBLY REMOVAL AND REPLACEMENT

Warning: The light assembly is extremely hot when operated and will cause burns if touched. **DO NOT attempt to touch or replace the light assembly unless it has been OFF and allowed to cool for at least 30 minutes.**

1. Remove the two screws securing the light assembly access cover and remove the cover.
2. The light assembly is positioned in the light assembly holder. To remove, pull the light assembly straight up.
3. Remove the light assembly from the light receptacle.
4. Take care to hold the new light assembly by the reflector, **DO NOT** touch the light bulb. Carefully position the light assembly and insert (pushing down) into light assembly holder. Replace with Quartz halogen lamp MR-16, type EYC. (Fiberstars part number HI-075).
5. Replace light assembly access cover.

POWER DIVERTER MAINTENANCE

If your spa's Power Diverters become difficult to turn, it is likely that sand or grit has become lodged inside the valve body. It is very important that this debris is removed as soon as possible to avoid damage to the valve. To accomplish this, follow this procedure:

1. Turn off power to the spa.
2. Remove the Power Diverter's handle by pulling upward while rocking it back and forth.
3. Unscrew the cap ring.
4. Remove the valve body by pulling it upward.
5. Wipe the valve body and the interior walls of the valve clean.
6. Lubricate the valve body with a waterproof lubricant available from your Caldera dealer.
7. Reassemble the valve and turn on power to the spa.

MAINTENANCE

SPA COVER CARE

CLEANING AND VINYL CARE Keep the cover clean. As often as is necessary wash with mild soap and rinse with clean potable water. **DO NOT USE SOLVENTS, PETROLEUM PRODUCTS, ABRASIVE CLEANERS OR STRONG DETERGENTS.** All vinyls contain plasticizers which migrate out and escape naturally over time. Sun and cold speed up this process. Applications of vinyl cleaner and conditioner, when used according to the manufacturer's instructions, may retard this type of deterioration. **DO NOT USE PRODUCTS THAT CONTAIN SILICONE OR ALCOHOL.**

CHEMICALS The vinyl and thread are marine treated but will deteriorate quicker when exposed to high levels of chlorine, bromine, ozone or other active chemicals. At the time chemicals are added, remove the cover completely and place it far enough away so splashing cannot inadvertently reach the cover. Chemicals should be added frequently at low levels instead of infrequently at high levels.

CARE OF SEWING HOLES AND THREAD The sewing holes and thread are the greatest potential weakness in a cover. Vinyl is a soft, leather-like material which the thread can cut if the cover is roughly handled. This is especially true when the vinyl has been exposed to hot sun. The handles, tie-downs and hinge are double reinforced with thick, vinyl coated, rip-stop polyester webbing. However, mistreatment by sudden jerking motions can damage them. Stretching or pulling one half against the other may rip the cover at the thread holes. To prevent damage, any handling of the cover should be done in a gentle manner.

Note: Fading and discoloration will occur naturally with extended exposure to the sun.

NON-OPERATION IN COLD CLIMATE

If the spa is to be left unused for an extended period of time in areas where **FREEZING TEMPERATURES DO NOT OCCUR**, it may be desirable to switch the spa to ECONOMY mode. When in ECONOMY mode, the spa water temperature is maintained within 20°F of the set temperature. The automatic filter cycles, along with occasional chemical treatments, will keep the spa water clean and sparkling. When preparing the spa for use, check the water chemistry to assure correct chlorine or bromine and pH levels.

You can keep the water in the spa during the time of year when freezing at the spa location may occur. When the spa water temperature is 20°F lower than the set temperature, the pumps and heater will be activated automatically to circulate the water. The LCD will display the "COOL" message.

CAUTION must be used with this approach. In the event of electrical power interruption, regardless of the cause, the heater and pump will stop operating and freeze protection will be lost, possibly resulting in freeze damage to the spa, spa plumbing and/or Control Module.

WINTERIZING YOUR SPA

If you wish to leave your spa empty and it is located where freezing temperatures occur, follow steps 1 thru 5 outlined in "DRAINING YOUR SPA" on page 16 then complete the following steps:

1. Refer to "EQUIPMENT LOCATION" page 13 and locate the Air pump and Hydro jet pump 1 and 2.

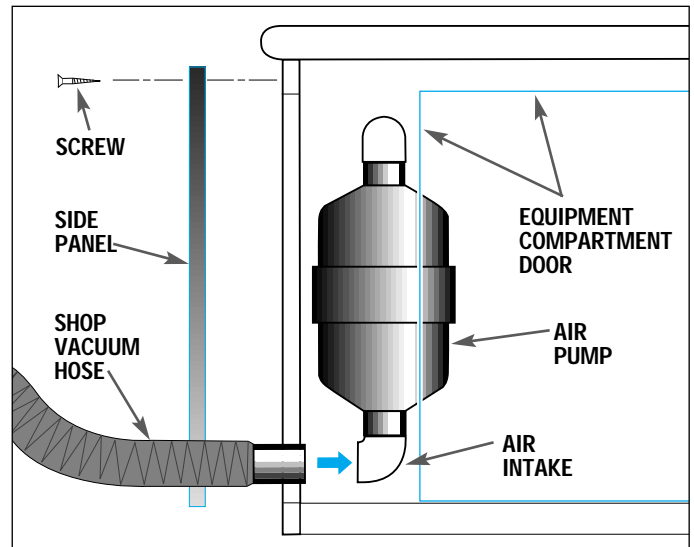

2. Remove the screws securing the spa side panel and remove panel (left hand side of spa when facing the spa-side control - not the equipment compartment door).

3. Attach a shop vacuum hose to the air intake of the Air pump, then operate the shop vacuum (**in blow mode**) for a few seconds until all water has been removed from the air jets and air channel.

NOTE: Make certain all power to the spa is **OFF** before you continue.

4. It will be necessary to remove all water from the interior plumbing. Refer to the illustration on page 6 to locate the drain/suction fittings. Remove the screws securing the drain/suction covers, then remove the suction cover by turning counter-clockwise.

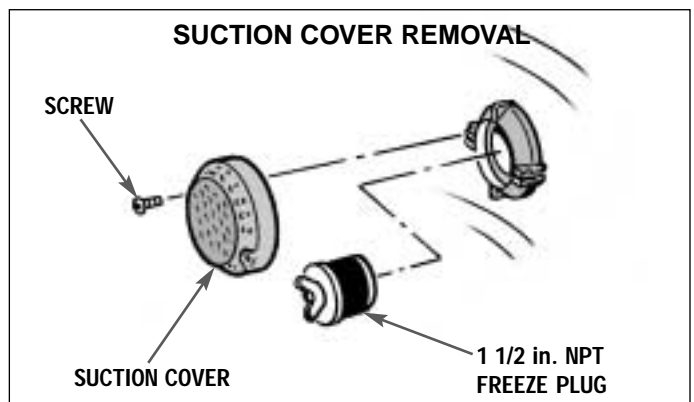

MAINTENANCE

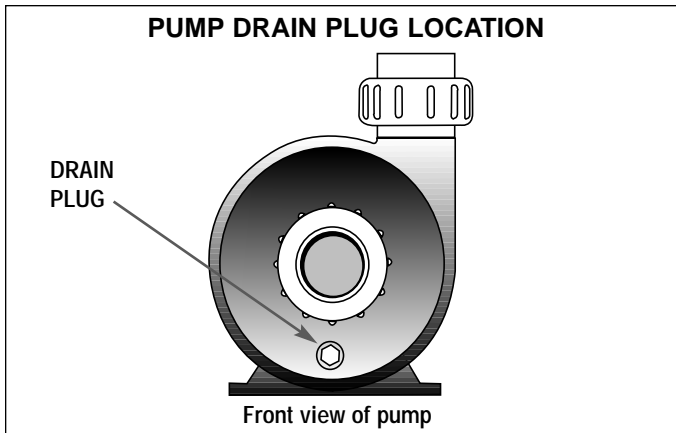

5. Follow the instructions on page 14 to remove the floating weir, basket and filter cartridge. Insert a shop vacuum hose into the suction line located in the bottom of the filter compartment (operate in the blow mode). If the vacuum hose does not fit tight into the opening, air will escape. It might be necessary to wrap a rag around the vacuum hose to make an air-tight seal.

6. With the vacuum blowing into the opening of the filter compartment, note that air escapes through one of the suction openings in the footwell. Close this suction opening by installing a 1 1/2" NPT "freeze plug" (available from a hardware store). Position all Power Diverters to "Combo" and operate the shop vacuum in blow

mode to blow all of the water out of the jet lines supplied by the dual-speed pump.

7. Note that there are two other suction openings in the sides of the footwell. Remove the freeze plug used in the previous step and install it in one of these openings. Insert the vacuum hose into the other suction opening and blow the water out of the jet lines supplied by the single-speed pump.

8. Remove the freeze plug, replace the suction covers and reinstall the screws to secure the suction covers.

9. Use a wrench to remove the pump drain plugs located on the front of the pump housings. Allow all water to drain out, then replace the pump drain plugs.

NOTE: DO NOT LEAVE ANY WATER IN YOUR SPA.

WARNING: When not in use, the spa must be covered with an insulating spa cover. Damage caused by either sun exposure or freezing is not covered under warranty.

DRAINING YOUR SPA

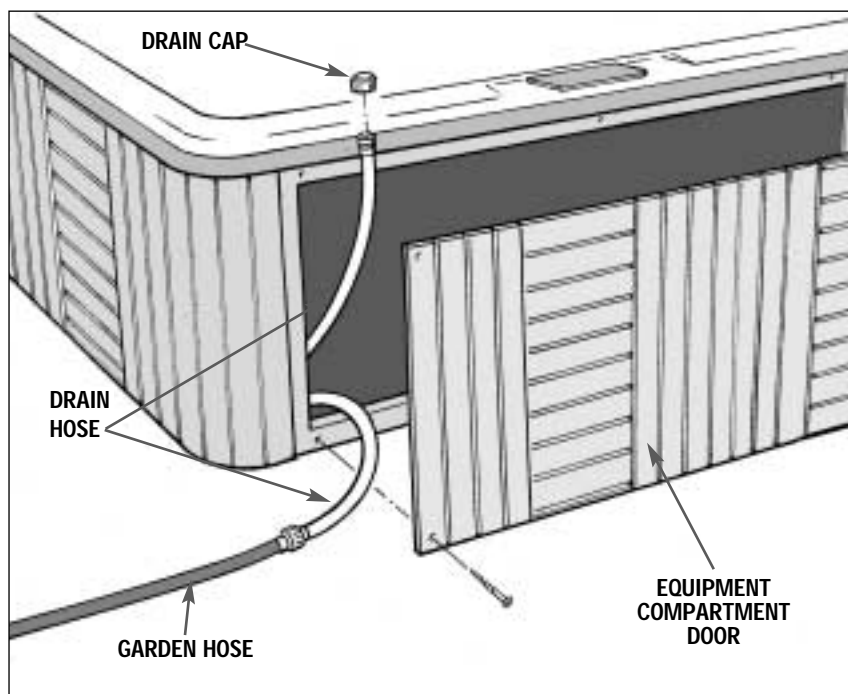

1. Trip all GFCI breakers in sub-panel, or main electrical panel.

2. Remove the equipment compartment access door.

3. Locate the end of the drain hose and lift it above the water level. (Requires clipping plastic tie the first time.)

4. Unscrew and remove the drain cap.

5. Attach drain hose to a garden hose and direct to an appropriate draining area, keeping the hose below the water line.

6. After your spa is empty, clean the shell and filter cartridge. See "IMPORTANT MAINTENANCE PROCEDURES" on page 12.

7. After cleaning, remove garden hose, replace drain cap and put drain hose back in equipment compartment.

8. Follow the "START-UP INSTRUCTIONS" on page 5 to refill your spa.

BALANCING THE SPA WATER

BALANCING YOUR SPA WATER

The instructions below will assist you with balancing the spa water for the first time. You will need the following items to balance your spa water.

1. "3-Way Test Strips"
2. "Spa Up" and "Spa Down" for pH control.
3. "Spa Defender" for calcium and scale control.
4. "Metal Gone" for breakdown of mineral deposits.
5. "Renew" for shock treatment.
6. "Bromine" or "Chlorine" for sanitizing the spa water.

Please read "WATER MAINTENANCE" on page 18 then follow these easy steps:

1. Fill your spa until the water level is 1 inch above the highest jet. It is **NOT** advisable to use softened water in your spa, as it may be corrosive.
2. Add 1/2 pint of Spa Metal Inhibitor (Metal Gone) to prevent iron or copper deposits from staining the finish of your spa. If your water is known to contain high concentrations of these metals it may be necessary to add an additional quantity of Spa Metal Inhibitor.
3. Use a 3-way spa water test strip or test kit to measure the pH and Alkalinity of your water. The following instructions utilize test strips for testing. Immerse the test strip in the spa water, following the instructions on the test strip container label. Compare the test strip to the label to determine the condition of the spa water.

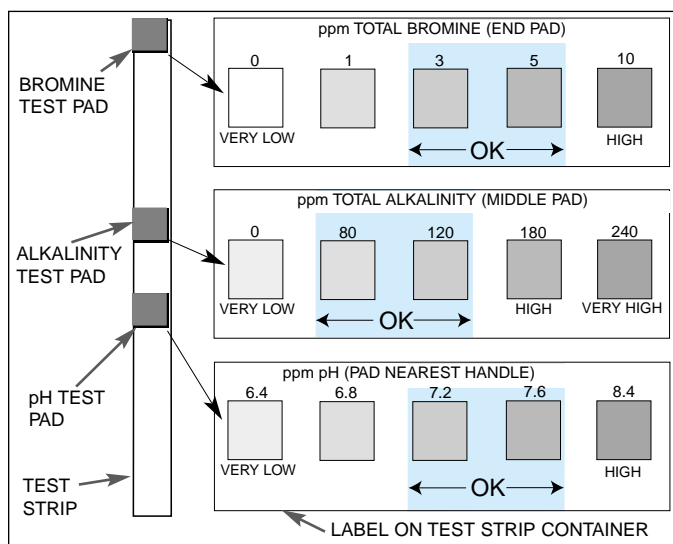

4. If the Alkalinity is not within the acceptable range (80 to 120 ppm) it should be adjusted first. If it is low, raise the Alkalinity by adding Spa Up (1 oz. at a time), retesting until the Alkalinity

reaches 120 ppm. If the Alkalinity is high, it should be lowered by using Spa Down (1 oz. at a time).

5. After the Alkalinity is properly adjusted, the pH is next. If the pH is above 7.8, use Spa Down (1 oz. at a time) to lower it to the acceptable range. If the pH is below 7.2, add Spa Up to bring it into the acceptable range. It is extremely important to NEVER allow the pH of your spa water to be under 7.0, as this can severely damage your equipment and will void the warranty.

6. Add sanitizer, either chlorine or bromine. For chlorine: Follow the directions on the bottle. Chlorine dissolves rapidly; you should get a reading on the test strip within minutes of application. For bromine: Follow the directions on your floating brominator. It is necessary to add sodium bromide only when the spa is being filled. Bromine tablets erode slowly, and it may take several hours before you will get a reading on the test strip. It may be necessary to adjust the floating brominator and/or your skim/filter time.

7. To properly maintain the chemical balance of your spa, follow the 3-day-a-week program outlined below:

3-DAY-A-WEEK SPA CARE PROGRAM

MONDAY

1. Test the water using 3-WAY SPA WATER TEST STRIPS.
2. Adjust pH and total alkalinity - Refer to pH and total alkalinity on label of SPA UP and SPA DOWN.
3. Maintain **1.0 to 3.0 ppm** bromine or free chlorine.
4. Add 1 ounce of SPA DEFENDER per 400 gallons of water to prevent calcium build up.
5. Shock treat with 2 ounces of RENEW, a non-chlorine shock, every week as needed.

WEDNESDAY

1. Nothing required if bromine is used as sanitizer. Check and adjust chlorine level if chlorine is used.

FRIDAY

1. Nothing required if bromine is used as sanitizer. Check and adjust chlorine level if chlorine is used.

Note: The above table is an example only. Actual spa usage will determine the amount of chemicals required to maintain proper chemical balance.

WATER MAINTENANCE

IMPORTANT: Your Caldera spa warranty **excludes** surface or component damage caused by poor water chemistry, the improper use or application of chemicals, or the use of non-approved chemicals, or failure to maintain pH within proper range. Spa shell, plumbing, electrical system, spa cover or other spa component failures resulting from the addition of any alternate water sanitation or purification device, heating system or the modification of the original equipment are **NOT** covered by your Caldera spa warranty.

DO NOT allow anyone to be in the spa while chemicals are being added or dissolving.

DO NOT use incorrect products such as Trichlor, which has a very low pH (2.6), dissolves very slowly, is highly concentrated and was designed for concrete or plaster swimming pools. It will cause damage to your spa!

WATER PURIFICATION WITH OZONE

The Caldera Pure Water Ozone system produces ozone to “burn out” water contaminants, bacteria and viruses through the process of oxidation. Ozone is continually produced and distributed to the spa during the filtration/skim/filter cycles.

Ozone does not replace traditional water sanitizing chemicals such as chlorine or bromine. A small amount of chlorine or bromine will be needed in the water in addition to ozone. Ozone will be doing the major job of killing microorganisms and oxidizing bather waste such as perspiration, body oil, suntan lotion, etc. The chlorine or bromine will be providing the measurable, lasting residual and preventing algae from growing.

DO’S AND DON’TS OF SPA WATER MAINTENANCE

DO read labels carefully and follow direction precisely. Though chemicals protect you and your spa when used correctly, they may be hazardous in a concentrated form.

DO add all chemicals slowly into the filter compartment with the Hydro jets operating in high speed.

DO handle all containers with care. Store in a cool, dry, well-ventilated place.

DO NOT use swimming pool chemicals in your spa.

DO NOT use household bleach (liquid sodium hypochlorine).

DO NOT use swimming pool (muriatic) acid to lower pH. Many swimming pool water care products can cause damage to spa surfaces and equipment.

DO NOT splash pH “increase” additives on the redwood cabinet during pH adjustment. Many pH “increase” additives will cause redwood to turn dark by pulling the tannin (reddish color in redwood) out of the wood.

ALKALINITY		
VERY LOW	0	ADD SODIUM BICARBONATE TO INCREASE
ACCEPTABLE ZONE	80	IDEAL
	120	
HIGH	180	ADD SODIUM BISULFATE TO DECREASE
VERY HIGH	240	

pH LEVEL		
TOO ALKALINE	8.4	ADD pH DECREASER TO LOWER pH
SCALING ZONE	8.2	
COMFORT ZONE	7.8	IDEAL
	7.6	
	7.4	
	7.2	
TOO ACIDIC	7.0	ADD pH INCREASER TO RAISE pH
CORROSIVE ZONE	6.8	

SANITIZER LEVEL	
ppm	DO NOT USE SPA UNTIL TEST KIT READING IS BELOW 5.0 ppm
5.0 -	RECOMMENDED LEVEL SAFE
4.0 -	
3.0 -	
2.0 -	
1.0 -	
0 -	DO NOT USE SPA ADD SANITIZER TO REACH RECOMMENDED LEVEL

SPA WATER TROUBLESHOOTING

SYMPTOM	PROBABLE CAUSE	SOLUTIONS
Cloudy Water	<ul style="list-style-type: none"> • Inadequate filtration/dirty filter. • Excessive oils/organic matter. • Improper sanitation. • High pH and/or high alkalinity. • Suspended particles/organic matter. • Overused or old water. • Ozone malfunction. 	<ul style="list-style-type: none"> • Clean filter with a filter cleaner or degreaser. • Shock the spa with "RENEW". • Increase sanitizer to recommended level. • Adjust pH; add "SPA DOWN". • Use clarifier. • Drain the spa, clean and refill. • Contact your Caldera dealer.
Water Odor	<ul style="list-style-type: none"> • Excessive organics/too many chloramines/bromamines - insufficient free available chlorine. • Improper sanitation. • Low pH. 	<ul style="list-style-type: none"> • Shock the spa with "RENEW". • Increase sanitizer level to recommended level. • Raise pH with "SPA UP".
Chlorine Odor	<ul style="list-style-type: none"> • Too many chloramines-insufficient free available chlorine. • Low pH. 	<ul style="list-style-type: none"> • Shock the spa with "RENEW". • Adjust pH; raise pH with "SPA UP".
Musty Odor	<ul style="list-style-type: none"> • Bacterial or algae growth. 	<ul style="list-style-type: none"> • Shock the spa . If problem is visible, draining and cleaning may be required.
Foaming	<ul style="list-style-type: none"> • Buildup of body oils, lotion and chemicals resulting in soap or detergent. • Overused or old water. • Excessive organics. 	<ul style="list-style-type: none"> • Add defoamer or drain and refill. • Drain and refill. • Shock with "RENEW".
Organic Buildup/Scum Ring Around The Tub	<ul style="list-style-type: none"> • Body oils and dirt. • Inadequate filtration. 	<ul style="list-style-type: none"> • Wipe off scum with a clean rag. Depending on severity - drain spa, use a spa surface and tile cleaner to remove the scum, refill spa and adjust water. • Clean filter with a filter cleaner or degreaser.
Algae	<ul style="list-style-type: none"> • High pH. • Low free chlorine/bromine. 	<ul style="list-style-type: none"> • Shock with "RENEW"; adjust pH. • Shock with "RENEW"; maintain sanitizer at recommended level.
Eye Irritation	<ul style="list-style-type: none"> • Low pH. • Insufficient free available chlorine/bromine. 	<ul style="list-style-type: none"> • Raise pH with "SPA UP". • Shock with "RENEW".
Skin Irritation/Rash	<ul style="list-style-type: none"> • Unsanitary/polluted water. • Chlorine/bromine level too high (above 5 ppm FAC). 	<ul style="list-style-type: none"> • Maintain recommended sanitizer residual at all times; super-chlorinate. • Allow chlorine/bromine level to drop below 5ppm before using spa.
Stains	<ul style="list-style-type: none"> • pH or total alkalinity too low. • High iron or copper in water source. 	<ul style="list-style-type: none"> • Adjust pH and total alkalinity; use sequestering agent; drain and clean with appropriate product. • Use sequestering agent for metals; adjust water.
Scale	<ul style="list-style-type: none"> • Too much calcium dissolved in water-pH. 	<ul style="list-style-type: none"> • Adjust total alkalinity and pH levels by adding the appropriate sodium bisulfate product; with concentrated scale deposits - drain the spa, scrub the scale off, refill the spa and balance the water.

SPA TROUBLESHOOTING

If your spa doesn't seem to be working the way you believe it should, please review the "START-UP" and "OPERATION" instructions in this manual. If this doesn't help you correct the problem, follow the appropriate instructions below. If the problem still is not resolved, call your Caldera dealer.

SYMPTOM	PROBABLE CAUSE	SOLUTIONS
Nothing works, Blank LCD screen	<ul style="list-style-type: none"> • Circuit breaker tripped or OFF. 	<ul style="list-style-type: none"> • Reset circuit breaker. • Reset GFCI.
Pump motor will not function	<ul style="list-style-type: none"> • Motor overload condition. • Control switch failure. 	<ul style="list-style-type: none"> • Let cool for 1 hour. Motor overload will reset automatically. If problem persists, contact your Caldera dealer. • Disconnect spa and contact your Caldera dealer.
Noisy pump or Motor	<ul style="list-style-type: none"> • Low water level. • Knife valves closed. 	<ul style="list-style-type: none"> • Add water to normal level (1 inch above highest jet). • Open all knife valves.
Pump motor runs, but low or no water/jet pressure	<ul style="list-style-type: none"> • Air control valve closed or blocked. • Low water level. • Dirty filter cartridge. • Knife valves partially or fully closed. • Jet blocked. • Clogged suction or skimmer basket. 	<ul style="list-style-type: none"> • Open or clean air valve. • Add water to normal level (1 inch above highest jet). • Clean filter cartridge. • Open all knife valves. • Remove jet face eyeball and clean orifice. • Clean suction cover or skimmer basket.
<p>Priming the pump</p> <p>Upon filling or refilling the spa, if a pump is operating and water is not flowing from any of its jets, the pump may not be properly primed. To correct, refer to the "Equipment Compartment" illustration on page 13 and perform the following procedures:</p> <ul style="list-style-type: none"> • Turn off power to the spa at the breaker and remove the equipment compartment door. • Loosen the union on the top of the pump to allow the air to escape. When water is present, hand-tighten the union. • Turn power back on, activate the pump and check to make sure union is tight enough to keep it from leaking. 		
Spa not heating properly	<ul style="list-style-type: none"> • Temperature set too low. • Spa cover improperly positioned. • Filter cycles too short in Economy mode. • Dirty filter cartridge. 	<ul style="list-style-type: none"> • Set control panel to a higher temperature. • Align spa cover. • Switch to standard mode and/or lengthen filter cycles. • Clean filter cartridge.
Power Diverters are difficult to turn	<ul style="list-style-type: none"> • Sand or grit inside valve. 	<ul style="list-style-type: none"> • Clean and lubricate valve per instructions on page 15.
Fiber Optics lighting (option) does not operate when switched on	<ul style="list-style-type: none"> • Light assembly failure. 	<ul style="list-style-type: none"> • Replace light assembly.
Fiber Optics lighting (option) color wheel does not rotate when switched on	<ul style="list-style-type: none"> • Power module failure. 	<ul style="list-style-type: none"> • Contact your Caldera dealer.

LCD MESSAGES

Pd **Power Down** - Power has been cut off to the spa. The battery backup is preserving the control panel settings. The control panel will be disabled until power is restored.

OH **Overheat Protection (spa is deactivated)** - If a malfunction occurs and spa water temperature reaches 112°F, the system will completely shut down. In such a condition, **DO NOT ENTER THE WATER**. Turn off all power to the spa and contact your Caldera dealer.

ICE **Freeze Protection** - If a potential freeze condition is detected, both Hydro jet pumps are automatically activated. This is a normal spa function; no corrective action is necessary. Freeze protection is enabled regardless of the spa's operating status.

ILOC **Irregular Voltage** - Irregular voltage to the control module or malfunction of the ozone unit is detected. To test for ozone malfunction, unplug ozone unit. The ozone plug is located on the right hand side of the control module. Reset the system at the breaker panel. If "ILOC" disappears after resetting, the ozone unit has malfunctioned. If "ILOC" reappears after resetting, contact your Caldera dealer.

FLO **Flow switch (constantly displayed)** - An air lock may have occurred (refer to "PRIMING THE PUMP(S)" on page 20 for priming instructions), or a flow switch has malfunctioned. Contact your Caldera dealer.

Flow Switch (flashing) - The flow switch is not detecting an adequate amount of water flow. Make sure the spa is filled to 1 inch above the highest jet. The spa will continue to operate, but the heater will not activate. Contact your Caldera dealer.

COOL **Temperature Set Back** - If the spa water temperature is more than 20°F cooler than the temperature set point, the heater will automatically activate to provide freeze protection. This is a normal spa function; no corrective action is necessary.

Sn1 **Open Sensor (spa is deactivated)** - The high limit temperature sensor is non-functional. This must be repaired only by your Caldera dealer or a qualified service organization.

Sn3 **Open Sensor (spa is deactivated)** - The water sensor is non-functional. This must be repaired only by your Caldera dealer or a qualified service organization.

SPA SPECIFICATIONS*

	GENEVA	NIAGARA
Dimensions:	92 in. x 92 in. x 38 in.	92 in. x 92 in. x 38 in.
Water capacity:	475 gal.	500 gal.
Weight - dry:	836 lbs.	836 lbs.
Weight - with water:	4,784 lbs.	4,991 lbs.
Pump 1:	2.0 hp, 2 speed, 240V	2.0 hp, 2 speed, 240V
Pump 2:	2.0 hp, single speed, 240V	2.0 hp, single speed, 240V
Air pump:	1 hp, 240V	1 hp, 240V
Electrical:	240V, 50 Amp	240V, 50 Amp
Heater:	240V, 4.0 kW	240V, 4.0 kW
Caldera Pure Water Ozone system option:	120V	120V
Filter:	75 sq. ft. cartridge	75 sq. ft. cartridge
Fiber Optics Lighting:	120V	120V

	TAHITIAN
Dimensions:	87 in. x 87 in. x 36 in.
Water capacity:	360 gal.
Weight - dry:	706 lbs.
Weight - with water:	3,694 lbs.
Pump 1:	2.0 hp, 2 speed, 240V
Pump 2:	2.0 hp, single speed, 240V
Air pump:	1 hp, 240V
Electrical:	240V, 50 Amp
Heater:	240V, 4.0 kW
Caldera Pure Water Ozone system option:	120V
Filter:	75 sq. ft. cartridge
Fiber Optics Lighting:	120V

**Dimensions, weights and capacities are approximate.*

Caldera Spas . . . Quality Spas and Gazebos Since 1976.